

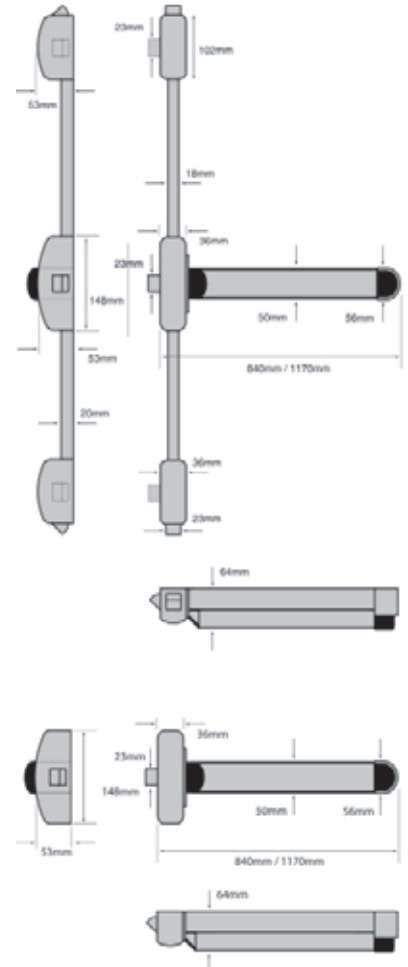

Motorised Touch Bar Range



Technical Drawings



Technical drawings applicable to PHTM0, PHTM5, PHTM7



All Panic Hardware devices (with full width touch bar) have been tested and certified to EN1125:2008 (Classification 3-7-7-B-1-4-2-2-B-A)

Strand Antipanic Motorised Touch Bar Range

- Similar in design to the standard touch bar, the motorised touch bar range comprises a full width touch bar and modular components.
- The range offers a large degree of flexibility and can provide 1, 2 and 3 point latches and 2 or 3 point bolts.
- Standard size motorised touch bar, 840mm, is suitable for doors up to 860mm wide, for doors exceeding these dimensions extra wide touch bars of 1170mm and 1300mm are available
- Can be connected to a variety of access entry systems such as a digital keypad, proximity reader or swipe card to allow controlled access from outside
- Operates on 12-30v DC or 12-20v AC
- 2 amp power supply

Application

- Supplied with striker plates for timber doors
- Strikers also available for PVC-U, Aluminium and Steel doors (Please specify when ordering)

Dogging facility:

Dogging should not be used on the fire/smoke door assemblies

- Not supplied as standard but is available with a dogging or hold-back facility (If required please specify when ordering)
- Can only be used on escape doors

Microswitch

- The motorised touch bar range can be provided with a microswitch contained in the operating mechanism
- If required please specify at the time of ordering stating

Outside access

- Optional outside access devices with lever handle or knob to provide entry from the outside (See page 14 for further information)



Finishes

Powder coated finishes

Silver EPS (20)
Black with Green cross arm BGN (81)

Plated finishes

Satin Stainless Steel Plated SSSP (44)

Touchclean™ antibacterial coating available to special order

Various other RAL colours and plated finishes are available on request.

Please contact us to enquire

PHTM0 Single Point Motorised Touch Bar Latch

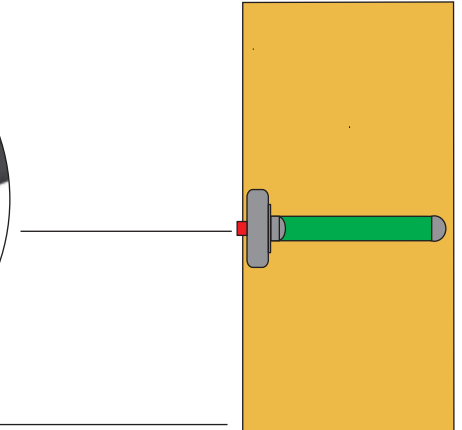

PHTM5 3 Point Motorised Touch Bar Bolt

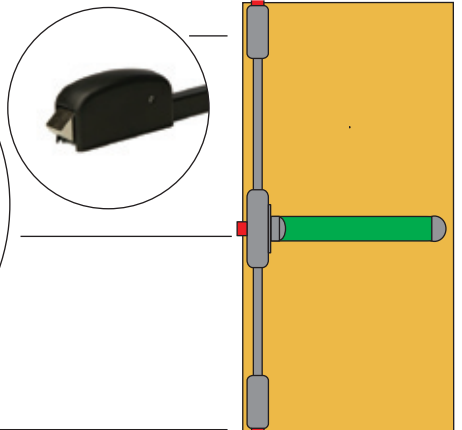

PHTM7 3 Point Motorised Touch Bar Latch

